

Feature Value Proposition

Capture video to support biological life surveys on the ocean floor.

Current State

None of our existing products have video capture functionality.

Customer Need

The overall objective for the Klickitat robot is to increase the safety, accuracy and efficiency of ocean floor biological surveys by performing remote controlled transect mapping of ocean floor habitats. For the robot to do that successfully, it needs the ability to document the plants and animals that it finds within the area that it is mapping.

In manual transect mapping, divers count the species found in a given area. While we don't expect the robot to be able to identify the species that it finds, the robot needs to provide a visual feed of information that it can rely to biologists on the surface that is clear enough and detailed enough to enable species identification.

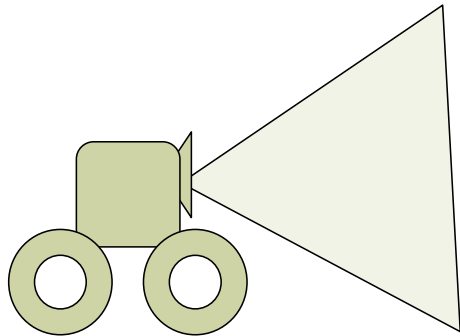

Implementation Alternatives Considered:

Criteria	Video Capture Only	Video Capture and Feed	Remote Control Video	Do Nothing
Capture biological survey data	+	+	++	0
Enable species identification	+	+	++	0
Improve accuracy	--	--	+	0
Improve safety	+	+	++	0

Recommendation:

We recommend implementing full remote control video.

Future State

The robot will collect video from the ocean floor and rely a feed to the crew on the surface. The biologists will use the remote control to zoom in on specimens that cannot be sufficiently identified. The biologists will then analyze the videotape to complete the biological survey.

Product Architecture Impact

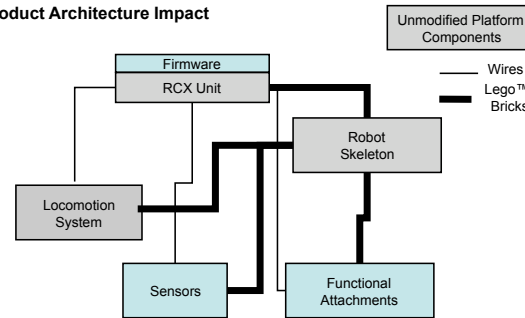

Major Impacts: How will the feature impact key dimensions of quality?

Area	Impact Level	Impact
Safety	Improve	Reduces need for dives
Performance	Improve	Provides permanent record
Compatibility	None	
Manufacturability	Degrade	Adds complexity
Set-up Needs	None	
Reliability	Degrade	Adds complexity
Serviceability	Degrade	Adds complexity

Risks: What risks will you actively monitor and mitigate?

Risk	Owner	Status	Mitigation Plan
Video resolution insufficient	Jim	Watch	User field tests with protos as early as possible
Water tight seals	Karen	Watch	Tank testing under pressure
UI Complexity	Steve	Watch	User field tests w/protos

Digital Video Capture

Klickitat - 07/2009

Katherine Radeka (katherine@whittierconsulting.com / 503-701-3945)

Resources Required:

Major Task	Est. Effort (hours)	Owner
Identify video components suppliers	40	Jim
Develop 1 st prototype set	240	Jim
Conduct 1 st round of field tests	80	Steve
Incorporate feedback	180	Jim
Complete 2 nd round of field tests	80	Steve
Detailed Component Design	360	Jim
Tooling and Process Design	180	Bob
Unit Testing	110	Chris
Integration Testing	250	Chris
Total Resources Required:	1340	

Major Milestones:

Feature Milestone	Date	Integration Milestone
1 st Proto Options Complete		SS1
User Field Tests – Round 1		SS2
User Field Tests – Round 2		SS3
Feature Complete		Sys1
Tooling and Process Complete		Sys2
All Tests Passed		PP

Approvals:

Approver	Signature
Attachments Manager	
Program Manager	
Product Marketing Manager	
Manufacturing Eng Manager	
Lab Manager	